

---

Version 5.4.0  
2/21/2025

## TABLE OF CONTENTS

<b>1</b>	<b>PURPOSE OF THIS DOCUMENT</b>	<b>4</b>
1.1	Purpose of This Technical specifications document	4
<b>2</b>	<b>OVERVIEW OF FUNCTIONALITY</b>	<b>4</b>
2.1	General Overview	4
2.1.1	Comprehensive Live and File-Based Inputs	4
2.1.2	Flexible Composition, Graphics Overlay, and Titling	4
2.1.3	Built-in Live Production Switcher through Skaarhoj	4
2.1.4	Exceptional Output Format Support	4
2.1.5	API-level Support for Facebook and YouTube Live	4
2.1.6	Unique Monetization Features	4
2.1.7	Broadcast Automation	4
2.1.8	Access Additional Functionality via Sister Products	4
2.1.9	Monitor Cambria Live through Web-UI	4
2.1.10	Encoders Software & Hardware GPU	4
2.2	Input Features	5
2.2.1	AJA Capture Card Support	5
2.2.2	4K Capture	5
2.2.3	Video File Input Support and File Playlist	5
2.2.4	Audio Input Support	5
2.2.5	Image File Input Support	5
2.2.6	PowerPoint Import and PDF	5
2.2.7	Animated Lower-Third and Other Motion Titles	5
2.2.8	IP Stream Input UDP/RTP/RTMP/SRT/NDI	5
2.2.9	Cambria Live Desktop Stream	5
2.2.10	Webcam Input	5
2.3	Composition, Production, and Switching Features	5
2.3.1	Integrated Live Production Switcher	5
2.3.2	Familiar Staging Preview to Program Output Operation	5
2.3.3	Intuitive Multi-Layer Function	6
2.3.4	Compositing	6
2.3.5	Multi-View Function: Virtual Cameras	6
2.3.6	Chroma Key Support	6
2.3.7	Audio Mixer and Level Control	6
2.3.8	Playlist Creation/Import	6
2.3.9	Sponsor Slate/Ad Slate	6
2.3.10	Scrolling Text Insertion	6
2.3.11	Real-Time Text/Layer Insertion	6
2.3.12	Closed Caption Support	6
2.3.13	Subtitle Support	6
2.3.14	Lip Sync Delay/Adjustment	6
2.3.15	Cambria Live Editor	6

# CAMBRIA LIVE CAMBRIA LIVE: TECHNICAL SPECIFICATIONS

2.3.16 Cambria Live Broadcast Manager	6
2.4 Distribution, Monetization, and Output Features	7
2.4.1 API-Level Access to YouTube Live	7
2.4.2 API-Level Access to FaceBook Live	7
2.4.3 Streaming to Akamai servers via ABR (HLS, DASH, CMAF)	7
2.4.4 Streaming to Web-DAV servers via ABR (HLS, DASH, CMAF)	7
2.4.5 Streaming to AWS MediaStore via ABR (HLS, DASH, CMAF)	7
2.4.6 Streaming to AWS S3 via ABR (HLS, DASH, CMAF)	7
2.4.7 RTMP Streaming to Wowza	7
2.4.8 RTMP Streaming to Brightcove	7
2.4.9 RTP/UDP and SRT/TS Generic RTMP Support	7
2.4.10 Comprehensive Output Format Support for Streaming/Recording	7
2.4.11 Select Output Source for Recording and Streaming Output	7
2.4.12 Extensive Presets Simplify Operation	7
2.4.13 DRM support for ABR outputs	7
2.5 Automation Features	7
2.5.1 Modern REST API	7
2.5.2 Comprehensive Logging Functionality	7
2.5.3 Event Notification	7
2.5.4 SDI Router	8
2.6 Cambria Live Editor Features (Separate Product)	8
2.6.1 Highlight Clip Edit	8
2.6.2 Preview Highlight Clips Live	8
2.6.3 Cambria FTC Transcodes and Upload Clips	8
2.6.4 Shared Marker Support	8
2.6.5 Cambria Live Assist	8
2.7 Cambria Live Broadcast manager	9
2.7.1 Overview	9
2.7.2 Programs	9
2.7.3 Machines	10
2.7.4 Redundancy	10
2.7.5 SDI Router	10
2.7.6 Monitoring	10
2.7.7 Output Preview	12
2.7.8 Ad Break Control	12
<b>3 MINIMUM SYSTEM REQUIREMENTS</b>	<b>12</b>
3.1 Operating System	12
3.2 Motherboard	12
3.3 Processor	13
3.4 System Memory (RAM)	13
3.5 Video Card	13
3.6 Network adapter	13
3.7 System hard drive	13
3.8 Recommended System for Cambria Live and Broadcast Manager	13
3.9 Recommended Settings for Cambria Live and Broadcast Manager	13
3.9.1 Windows Settings:	13

<b>4 OPERATIONAL MODES AND LICENSING MODELS</b>	<b>13</b>
4.1 Operational Modes	14
4.1.1 Standalone operation	14
4.1.2 Cluster operation	14
4.2 Licensing models	14
<b>5 SUPPORTED FORMATS</b>	<b>14</b>
5.1 Live Inputs/outputs	14
5.2 Import file formats	15
5.2.1 Source File Guidelines:	15
5.2.2 Input formats:	16
5.3 output file formats	16
<b>6 PERFORMANCE BENCHMARKS</b>	<b>17</b>
6.1 Benchmark Machine	17
6.2 Benchmark Configuration 1: HD I/O no Source Switching	17
6.3 Benchmark Configuration 2: Mixed Source Composition Switching	17
6.3.1 Performance Considerations	18
6.4 Broadcast Manager Test Configuration	18

## 1 PURPOSE OF THIS DOCUMENT

### 1.1 PURPOSE OF THIS TECHNICAL SPECIFICATIONS DOCUMENT

This document provides an overview of the Cambria Live encoder and its functionality, differentiates the available versions, identifies key features, and details the minimum system requirements and available licensing options.

## 2 OVERVIEW OF FUNCTIONALITY

Cambria Live is a software-based production suite for professional live streaming broadcast production. This all-in-one system handles live switching production functions, encoding, ad insertion and distribution.

### 2.1 GENERAL OVERVIEW

#### 2.1.1 Comprehensive Live and File-Based Inputs

Input a variety of live and VOD sources at up to 4K, including a live desktop from computers on the same network, local webcam input, and PowerPoint files for training and presentations.

#### 2.1.2 Flexible Composition, Graphics Overlay, and Titling

Compose multiple inputs into a single scene including picture-in-picture, chroma key, graphics overlays, and titles. Save scenes as compositions that can instantly be recalled and fed into the program output, which can be a live stream or file recording.

#### 2.1.3 Built-in Live Production Switcher through Skaarhoj

Fully integrated with Skaarhoj for remote control. Switch between any video source, including live capture input, video files, and playlists, on the fly while streaming. Control audio volume on the fly for multiple audio sources through a built-in mixer.

#### 2.1.4 Exceptional Output Format Support

Encode video into DASH/HLS/CMAF encoding ladders for immediate distribution or encode a single high-quality stream for RTMP distribution to end-points like Facebook Live, Youtube, Wowza, Uliza, Microsoft Azure and Brightcove. Also supports output via SDI.

#### 2.1.5 API-level Support for Facebook and YouTube Live

Login to your Facebook and YouTube Live accounts and Cambria Live manages all system level handshakes, protocol selection, and stream formatting to enable simple, high-quality productions.

#### 2.1.6 Unique Monetization Features

Supports SCTE-35 and SCTE104 ad insertion, server side ad insertion (Yospace, Brightcove), YouTube ad insertion.

#### 2.1.7 Broadcast Automation

Control Cambria Live via the Windows-based UI or REST API, command line plugin, with a scheduler, live machine failover, and other automation features.

## 2.1.8 Access Additional Functionality via Sister Products

Sister products include Cambria Live Editor (to create highlights on separate computers), Cambria Live Broadcast Manager, Cambria Ad Break Control, Cambria FTC and Cambria Live Packager.

## 2.1.9 Monitor Cambria Live through Web-UI

Users are able to remotely monitor Cambria Live instance through a Web-UI.

Use-case: Skaarhoj remote control users are able to monitor Cambria Live remotely through Web-UI. Cambria Live has its own version of a Web UI located at <https://hostname:8181>. You can also access this location from Cambria Live via Help > Launch Live Web UI.

The current version of Cambria Live Web UI is meant to be read-only. This means that you can view live programs, event logs, and ad switching, but you cannot perform any actions from the Web UI that change a Live instance's behavior. The add/edit functionality is still reserved to Cambria Live Desktop UI and Cambria Live REST API.

Not all of the Desktop UI features have been added to Web UI. Currently only these are viewable:

- Logs
- Targets
- Staging Preview
- Program Output
- Ad Break Window
- Source List

## 2.1.10 Encoders: Software CPU based & Hardware GPU based

**CPU based encoding:** Cambria Live integrates x264 and x265 encoders to ensure the highest-quality video output. Fully licensed and integrated with x264 for H264 codec and x265 for HEVC codec.

**GPU based encoding:** Cambria Live uses Nvidia cards with NVENC for hardware based encoding.

7th NVENC Generation (or newer) Qualified GPUs are recommended for better performance and least limitations. For a list of GPUs, please visit

<https://developer.nvidia.com/video-encode-and-decode-gpu-support-matrix-new>

**The only officially supported card (Capella tested):**  
**PNY NVIDIA Quadro RTX 4000**

H264 NVENC codec was added to all Live targets except for YouTube (MPEG-DASH). In the encoding settings, the user can find this option in the codec dropdown.

Note: the user must have an H264 (NVENC) license and supported graphics card in order to use this. Cambria Live will provide an error in the "Status" column if no proper graphics card was detected or if the graphics card driver version needs to be updated.

NVIDIA NVENC support significantly accelerates HEVC encoding speeds. HEVC (NVENC) was added to the following Cambria Live targets:

- RTP
- SRT
- Zixi
- File
- CMAF
- DASH

Users can find this option in the encoding settings of the Cambria Live target under the codec dropdown.

Note: User must have a valid HEVC (NVENC) license and supported graphics card in order to use this. Cambria Live will provide an error in the "Status" column if no proper graphics card was detected or if the graphics card driver version needs to be updated.

## 2.2 INPUT FEATURES

### 2.2.1 AJA Capture Card Support

Cambria Live supports four OEM capture boards from AJA(Corvid 88 – 8 I/O channels; Corvid 44 – 4 independent channels; Kona LHi – single channel (SDI/HDMI); Kona 1 – single channel).

### 2.2.2 4K Capture

Cambria Live supports real-time 4K capture and encoding using the AJA HEVC 4K capture board (under development) and AJA Corvid 44 and Corvid 88 cards

### 2.2.3 Video File Input Support and File Playlist

Cambria Live can import numerous video file formats, including MP4, TS, WMV, and MOV files and use them as sources during a broadcast. Includes support for source. Via right-click control, can elect "Use Resume Playback" so operator can switch to a different source file during media playback and playback will resume at that location when media is switched back to live. File sources can also be organized into Playlists.

### 2.2.4 Audio Input Support

Input audio files in WAV and WMA formats and capture audio from any microphones and other audio sources connected to the Cambria Live computer. Also able to import audio as a WaveIn source inside the Picture in Picture settings.

### 2.2.5 Image File Input Support

Cambria Live can import still image files in BMP, JPG, JPEG, PNG, TIF, TIFF, TGA, and TPIC formats.

### 2.2.6 PowerPoint Import and PDF

Users can integrate PowerPoint presentations and PDF files into a live broadcast for E-learning, webinars, and other presentations.

### 2.2.7 Animated Lower-Third and Other Motion Titles

Users can build animated lower thirds in programs like Adobe AfterEffects which are saved as MOV files with an alpha channel. These files can be imported into Cambria live with animation playback controlled within the PiP window.

### 2.2.8 IP Stream input: UDP/RTP/RTMP/SRT/NDI

Use an incoming UDP/RTP/RTMP/SRT/NDI live stream as a live capture input.

### 2.2.9 Cambria Live Desktop Stream

The Cambria Live Desktop Stream application transmits the image of a computer desktop across the network for broadcast applications. It can be installed on any workstation connected to the same network as Cambria Live.

### 2.2.10 Webcam Input

Cambria Live can input webcams connecting via DirectShow.

## 2.3 COMPOSITION, PRODUCTION, AND SWITCHING FEATURES

### 2.3.1 Integrated Live Production Switcher

Switch between any video source, including live inputs, video files, and playlists, on the fly while streaming via the app, API, or Skaarhoj remote control switcher.

### 2.3.2 Familiar Staging Preview to Program Output Operation

Cambria Live uses the side-by-side preview/program output operation that allows operators to queue videos in the preview window and then switch between any video source, including live inputs, video files, and playlists, on the fly while streaming and/or recording.

### 2.3.3 Intuitive Multi-Layer Productions

Cambria Live deploys three classes of assets: full screen source, PiP/Audio, and Layers. Source files can be from real time capture or disk-based media as can the PiP/Audio layer, which is mixed and positioned in a staging window. Layers are comprised of still images, and still and moving titles. All content can be switched into and out of the production via a simple click, API call or a command from Skaarhoj.

### 2.3.4 Compositing

Producers can create multiple compositions with layers of videos, text, and picture-in-picture. During a program, the producer can switch between different presets which can also be saved for later reuse in different productions.

### 2.3.5 Multi-View Function: Virtual Cameras

Replicate the feel of a multi-camera broadcast by creating virtual cameras in software that can be cued like multiple studio cameras.



### 2.3.6 Chroma Key Support

Produce real-time chroma key operations on your sources during a broadcast. Select a color and replace all occurrences of that color in a video or image with a transparency so that another video/image can be shown.

### 2.3.7 Audio Mixer and Level Control

An integrated audio mixer enables slider control over all audio inputs. You can also normalize incoming audio levels on the fly while live streaming, with both manual and automatic normalization.

### 2.3.8 Playlist Creation/Import

Create playlists with a group of files for repeated playback, highlight clips edited in Cambria Live, or a playlist to be muxed with a separate audio track. During playback, playlists can be reordered and assets skipped on the fly. Via right-click control, can elect "Use Resume Playback" so operator can switch to a different source or playlist during media playback and playlist playback will resume at that location when media is switched back to live.

### 2.3.9 Sponsor Slate/Ad Slate

Can designate a file as an Ad slate or sponsor slate to play insert into production when Ad or sponsor message is supposed to be playing, so if Ad or sponsor message fails, viewers will see the slate rather than live action.

### 2.3.10 Scrolling Text Insertion

Set the direction of scrolling text along with the font, point size, and color, all of which can be changed on the fly during a broadcast.

### 2.3.11 Real-Time Text/Layer Insertion

Insert text while streaming; specify font, point size, color, position, size, transparency and other attributes on the fly.

### 2.3.12 Closed Caption Support

Decode 608/708 captions in capture sources and send to YouTube, RMTP, RTP, SRT and TS file targets. Closed captions are supported in SDI and RTP sources only for now.

### 2.3.13 Subtitle Support

Teletext subtitles are supported in SRT and RTP sources. For HLS/TS split (non-interleave) and MPEG-DASH targets, the user can now select Teletext as the form of input for subtitles and output to WebVTT.

For teletext subtitles, the user must set the teletext page number in decimal (not hexadecimal). In order for teletext to be extracted from a source, the "Use Subtitle Extract from source" option in the "Options" menu bar tab must be enabled (checked). For RTP and SRT capture sources with teletext, it is recommended to set the latency mode to "Prioritize Stability" to maintain stability of stream while subtitles are extracted

Cambria Live now supports converting ARIB STD B37 subtitles from SDI to WEBVTT captions inside HLS and Dash (not supported in CMAF)

Cambria Live is also able to convert ARIB STD B37 (in SDI) to ARIB STD B24 (to TS based streams).

# CAMBRIA LIVE CAMBRIA LIVE: TECHNICAL SPECIFICATIONS

Full list of ARIB STD options:

- Embed ARIB STD B-37 in SMPTE2038 format to Target Stream:

Capturing ARIB STD B-37 data from SDI's VANC input and embed to TS-based streams based on SMPTE2038 spec. TS-based streams: TS File, RTP/TS, SRT/TS, Zixi/TS

- Embed ARIB STD B-37 in ARIB STD B-40 format to Target Stream:

Capturing ARIB STD B-37 data from SDI's VANC input and embed to TS-based streams based on ARIB STD B-40 spec. TS-based streams: TS File, RTP/TS, SRT/TS, Zixi/TS

## 2.3.14 Lip Sync Delay/Adjustment

Adjust lip sync delay during a broadcast to maintain audio/video synchronization.

## 2.3.15 Cambria Live Editor

Built in editor for creating highlight clips simultaneously during an event.

There is also a standalone version (at additional cost) can be installed on any computer on a Cambria Live network. Editors on separate workstations can create highlight clips simultaneously during an event.

## 2.3.16 Cambria Live Broadcast Manager

The Cambria Live Broadcast Manager is specifically designed for streaming broadcasters handling a high-volume, automated live streaming workflow with commercial ad insertion. This highly scalable solution manages multiple Cambria Live workstations over a network monitoring scheduled events, job failover, email notifications and monitoring, SDI rerouting, and regular machine maintenance with redundancy support. Cambria Live Broadcast Manager offers a cost-effective alternative to hardware encoders within a fully automated live streaming workflow.

## 2.4 DISTRIBUTION, MONETIZATION, AND OUTPUT FEATURES

### 2.4.1 API-Level Access to YouTube Live

Stream directly to a registered YouTube Live channel by entering your account information in Cambria Live. Cambria Live also integrates with YouTube's ad insertion feature, allowing the user to insert YouTube Live ads during a broadcast. Create YouTube events directly from BCM. Cambria Live is able to stream to Youtube using either the RTMP or MPEG-DASH protocols.

### 2.4.2 API-Level Access to FaceBook Live

Stream directly to a registered FaceBook Live channel by entering your account information in Cambria Live. Protocol used is RTMP.

### 2.4.3 Streaming to Akamai servers via ABR (HLS, DASH, CMAF)

Can stream to Akamai servers via HLS, CMAF (including CMAF-CTE chunked), and MPEG-DASH formats.

### 2.4.4 Streaming to WebDAV servers via ABR (HLS, DASH, CMAF)

Can stream to WebDAV servers via HLS, CMAF (including CMAF-CTE chunked), and MPEG-DASH formats.

## 2.4.5 Streaming to AWS MediaStore via ABR (HLS, DASH, CMAF)

Can stream to AWS Media Store via HLS, CMAF (including CMAF-CTE chunked), and MPEG-DASH formats. User will need to enter AWS MediaStore End Point along with Subfolder, AWS Region, AWS Access Key ID, and AWS Secret Key.

## 2.4.6 Streaming to AWS S3 via ABR (HLS, DASH, CMAF)

Can stream to AWS S3 via HLS, CMAF (including CMAF-CTE chunked), and MPEG-DASH formats. User will need to enter AWS S3 Bucket name along with Subfolder, AWS Region, AWS Access Key ID, and AWS Secret Key.

## 2.4.7 RTMP Streaming to Wowza

Enter Wowza account information in Cambria Live to stream via RTMP to a Wowza Streaming Engine or Wowza Streaming Cloud.

## 2.4.8 RTMP Streaming to Brightcove

Enter Brightcove account information to stream via RTMP to Brightcove servers with option for server-side advertising insertion (SSAI) via ID3 tags.

## 2.4.9 RTP/UDP and SRT/TS Generic RTMP Support

Supports distribution via RTP/UDP and SRT/TS to any compatible server. Can distribute to generic RTMP server if no service-specific preset exists, all with connection testing to simplify setup and operation.

## 2.4.10 Comprehensive Output Format Support for Streaming/Recording

Encode program stream to H.264 output in single file MP4 or TS or HLS, DASH, or CMAF formats for immediate distribution and/or archiving. Users can split long productions into multiple files for easier transfer, storage, and deployment.

## 2.4.11 Select Output Source for Recording and Streaming Output

Can select source other than program output for all file outputs, for example, to eliminate logos, titles, and other overlays from saved or streamed media. Recording individual sources through ISO workflow.

## 2.4.12 Extensive Presets Simplify Operation

All output presets have selectable streaming/recording encoding presets for a single file or adaptive bitrate groups ranging from 240p to 1440p. Users can choose the output preset that supports their resolution targets and/or outbound bandwidth and be assured that the output streams are properly configured. Users are also able to manually configure their presets up to 4k resolution.

## 2.4.13 DRM support for ABR outputs

Cambria Live supports multi-DRM via CPIX (v1 and v2 (v2.3) ) and is compatible with all major DRM systems. DRM providers: CPIX, Irdeto and Axinom. EZDRM is supported through CPIX v2 (v2.3)

DRM Types are:

- 1) HLS/TS, HLS/MP4, - Fairplay
- 2) DASH - Widevine or PlayReady
- 3) -CMAF/DASH - Widevine or PlayReady  
-CMAF/HLS - Fairplay

## Full List of supported distribution targets:

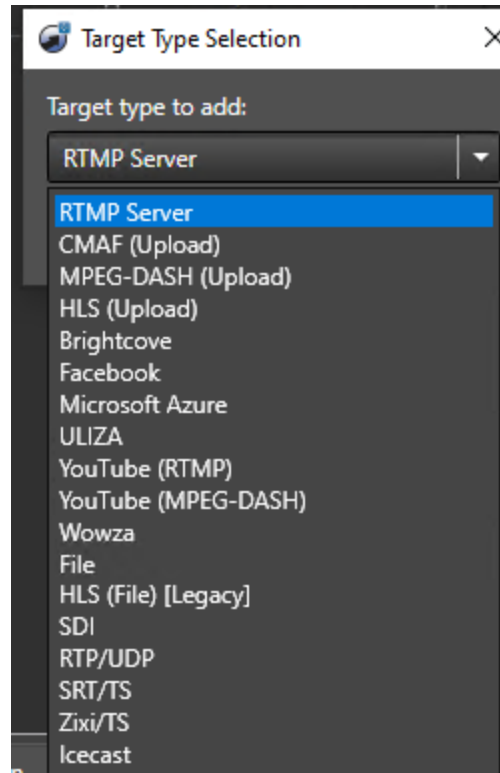

## 2.5 AUTOMATION FEATURES

### 2.5.1 Modern REST API

All aspects of the live production can be controlled via the Rest API, including switching and Ad insertion. Cambria Live's REST architecture is similar to popular APIs such as Facebook or Twitter and is familiar to developers.

### 2.5.2 Comprehensive Logging Functionality

The system can log all events during a broadcast and save the log files manually or automatically.

### 2.5.3 Event Notification

The system can send notifications as follows:

<b>Email Notification</b>	<ul style="list-style-type: none"><li>● Information<ul style="list-style-type: none"><li>○ Streaming starts</li><li>○ Streaming stops</li></ul></li><li>● Source check<ul style="list-style-type: none"><li>○ Streaming assets become unavailable</li></ul></li><li>● General running error<ul style="list-style-type: none"><li>○ Streaming error</li></ul></li><li>● Controller plug-in<ul style="list-style-type: none"><li>○ Information</li></ul></li></ul>
---------------------------	--

	<ul style="list-style-type: none"> <li>o Warning</li> <li>o Error</li> </ul>
<b>Twitter Notification</b>	<ul style="list-style-type: none"> <li>● On streaming start</li> <li>● On streaming stop</li> <li>● On streaming error</li> <li>● Periodically while streaming</li> </ul>
<b>Sound Notification</b> (audible beeps of configurable length and duration)	<ul style="list-style-type: none"> <li>● On streaming start</li> <li>● On streaming stop</li> <li>● On streaming error</li> <li>● Periodically while streaming</li> </ul>

## 2.5.4 Timed Actions.

Cambria Live can automate actions based upon production time or wall clock time. The actions can be saved as Timed Action Preset Files that can be reused in future productions. Automatable actions include:

- Auto-start streaming
- Switch sources/layers
- Switch between capture and triggered sources
- Stop streaming
- Change target state
- Switch Skaarhoj Controller

## 2.5.5 SDI Router

Capella Cambria Broadcast Manager uses the AJA SDK to control the KUMO SDI router so that SDI inputs associated to the project can be mapped to the Cambria Live running the project. Use KUMO as an affordable automated patch panel by routing the desired input to the appropriate Cambria Live machine.

## 2.5.6 Live Global Project options:

### -Capture VANC Data:

Capture VANC is used for following features: Closed Caption and SCTE-35/104

### -Use Genlock:

When Genlock is ON, all SDI in/out will try to sync against the external reference signal if present

### -Use Subtitle Extract Mode from Source:

When this setting is ON, subtitle metadata will be extracted from the source.

For RTP/SRT capture input, Latency needs to be changed to "Prioritize Stability" to avoid frame drop

### -Tolerate parsing/decoding error in Sources

When this setting is ON, parsing/decoding error will be more tolerated. It will be useful when using an unstable IP stream input

### **-Sustain GOP Structure with Splice Point**

When this setting is ON, the output GOP structure will be sustained even if a key frame of a start/end point (Splice Point) is inserted

### **-Use GOP boundary/PTS Sync Mode**

When it is turned on, GOP boundary will be synced in all targets, and PTS will be synced in all TS-based targets. It is needed to share encoders among ABR targets. Also, it will be useful when sending multiple RTP/TS streams to Cambria Stream instance

### **-Use Low Latency Mode**

In Low Latency Mode, the following latency will be minimized than normal mode by reducing internal buffer:

- Preview
- Target Output
- Switching Sources

### **-Use Accurate Reference Clock**

When this check box is ON, Live will sync internal reference clock to NTP server.

Doing so, Cambria Live can generate frames more accurately to avoid drifting over the time

### **-Use Delayed Capture Mode (for Capture Card)**

In Delayed Capture Mode, Live can accurately handle switching request by SCTE/ARIB signal without having preroll

## 2.6 CAMBRIA LIVE EDITOR FEATURES (SEPARATE PRODUCT)

### 2.6.1 Highlight Clip Edit

Use Cambria Live Editor installed on a separate computer to set in/out points and create highlight clips during a live streaming event. Find and set the in/out points on the Cambria Live Editor timeline to output multiple clips. You can then import these clips back into Cambria Live as a source for restreaming. Build a highlight playlist that can be played back even while a broadcast is still live.

### 2.6.2 Preview Highlight Clips Live

After setting in/out points, the user can preview the segment before submitting the clip back to Cambria Live for restreaming or to Cambria FTC for transcoding.

### 2.6.3 Cambria FTC Transcodes and Upload Clips

Send in/out edit points to Cambria FTC to transcode and output multiple file formats for VOD service, even during a live broadcast. Have all your highlight clips ready for VOD or restreaming before your live event ends.

### 2.6.4 Shared Marker Support

Markers set on the Cambria Live timeline will also display in Cambria Live Editor for an editor to select more precise in/out points. Markers can be set in different colors to identify specific events for rough cuts.

### 2.6.5 Cambria Live Assist

Cambria Live Assist is a standalone application that allows users to easily create Cambria Live projects on any workstation across the Cambria Live network.

## 2.7 CAMBRIA LIVE BROADCAST MANAGER

### 2.7.1 Overview

The Cambria Live Broadcast Manager is specifically designed for streaming broadcasters handling a high-volume, automated live streaming workflow with commercial ad insertion. This highly scalable solution manages multiple Cambria Live workstations over a network, monitoring scheduled events, job failover, SDI rerouting, and regular machine maintenance with redundancy support. Cambria Live Broadcast Manager offers a cost-effective alternative to hardware encoders within a fully automated live streaming workflow.

### 2.7.2 Program Scheduler



#### Overview:

Allows broadcasters to automatically start and stop streams of registered live events broadcast via Cambria Live. Users can preset multiple live events with individual project settings and recurring timetables. It also includes a pre-roll feature for cueing pre-prepared content before any scheduled event. Configurable program settings include:

- **Name and Description.**
- **Frequency.** One time, daily, weekly.
- **Maximum Retry Duration if event fails.**
- **Starting date, time and ending time (or none if unlimited duration).**
- **Kumo port routing for capture port.**
- **Cambria Live machine assignment.**

## 2.7.3 Machines

- **Overview.** Users can add, remove, and control all Cambria Live installations from a single user interface. Controls include:
- **Program assignments.** Assigning programs to a Cambria Live instance or allowing Broadcast Manager to control.
- **Failover.** Automatically reassign a job to an available Cambria Live workstation in case of a failure on the network. Can launch two identical projects simultaneously using same SDI input and stream to primary and backup publishing points for immediate failover.
- **Project density.** Set the number of programs that can be run on any single Cambria Live instance.
- **Monitoring.** Monitor the encode speed, network speed, CPU usage, memory usage, IP Address, Uptime, and the Cambria Live Version on any Cambria Live instance.
- **Scheduled Machine Maintenance.** The Cambria Live Broadcast Manager monitors the health of each Cambria Live workstation on the network. It can conduct scheduled reboots of the workstations to avoid possible failures.
- **Remote Desktop.** Open a remote desktop to the Cambria Live instance for additional monitoring and control.

## 2.7.4 Redundancy

- **Overview.** Cambria Live Broadcast Manager can be made fully redundant by adding a backup Cambria Live Broadcast Manager. In the event of a failure to the main Cambria Live Broadcast Manager, the backup takes over immediately without downtime.
- **Operation.** Can assign each Live Broadcast Manager instance a redundancy role (Primary, Backup, No Backup, Stopped). Backups monitor primary machine and automatically assume operation in the case of failure.

## 2.7.5 SDI Router

- **Overview.** Users can map the physical routing in the broadcast studio to inputs and outputs from SDI routers/switchers. SDI routing is supported natively through AJA KUMO SDI router.

## 2.7.6 Monitoring

- **Overview:** Users can send email notifications as follows:

<b>Machine</b>	<ul style="list-style-type: none"><li>● Cambria Live is unlocked</li><li>● License expiration</li><li>● Machine has not been rebooted</li><li>● Periodically send machine status</li></ul>
----------------	--



	<ul style="list-style-type: none"> <li>Running out of disk space (Broadcast Manager)</li> </ul>
<b>Program (Information)</b>	<ul style="list-style-type: none"> <li>Prior to program</li> <li>Streaming starts</li> <li>Streaming stops</li> </ul>
<b>Currently Used Capture Source Property Detection</b>	<ul style="list-style-type: none"> <li>Black frames</li> <li>No Closed Caption</li> <li>No timecode</li> <li>No triggered source switching signal</li> <li>Silent audio</li> </ul>
<b>Sources Check</b>	<ul style="list-style-type: none"> <li>File source is not accessible</li> <li>Streaming source becomes unavailable.</li> </ul>
<b>General Running Program Error</b>	<ul style="list-style-type: none"> <li>Program / streaming error</li> <li>Low disk space (Target)</li> <li>Low processing or delivering speed</li> <li>Target becomes disabled</li> </ul>
<b>Controller Plug-in</b>	<ul style="list-style-type: none"> <li>Information</li> <li>Warning</li> <li>Error</li> </ul>
<b>Redundancy</b>	<ul style="list-style-type: none"> <li>Changes in redundancy</li> </ul>

## 2.7.7 Output Preview

- Overview.** Displays program output from all running programs. Capabilities include:
- Status bars.** Show the status of encoding and network performance.
- Remote desktop.** Open a remote desktop to the Cambria Live instance for additional monitoring and control.

## 2.7.8 Ad Break Control

- Overview:** Cambria Broadcast Monitor supports a variety of advertising related workflows, including:
- Manual ad triggering.** Can use an Ad preset, reuse an Ad break, and adjust start and end points.
- SCTE-35, SCTE104 commercial cue tone support.** Recognizes SCTE104/SCTE35 commercial cue tones and can call for YouTube ad insertion on the fly to replace ads from an incoming broadcast being used during a live streaming event. Ingest SCTE104 from Grass Valley's K2 summit 3G media server and encode to RTMP with SCTE35 for automatic ad insertions. Includes switching and Ad adjustments, the ability to use SSAI, and to shorten Ad content from the source by start and/or end point.
- ARIB STD B39 Support.** Can capture ARIB STD-B39 signal from SDI input. Can set status bit for Ad and sponsor, set preroll for Ad and

# CAMBRIA LIVE CAMBRIA LIVE: TECHNICAL SPECIFICATIONS

Sponsor, set switching adjustment, use SSAI, define default Ad break and Sponsor Break, and set Ad adjustment.

- **Timecode based ad signaling.** Includes switching and Ad adjustments, SSAI, the ability to shorten ad content from Ad End Point or offset to source frame, and advanced ad control (prefetch/emergency/cancelation).
- **API-based cues.** Includes support for ESAM-based ad signaling (per CableLabs) and software cues. Can set Ad adjustment via start and end point, shorten ad content from Ad End Point or offset to source frame, and use SSAI with advanced ad control (prefetch/emergency/cancelation).
- **YouTube Ad Insertion.** Trigger/insert Google ads based on commercial cue tones from a master control or manually from the Cambria Live UI. Supports YouTube ad insertion via SCTE35 or SCTE104.

## 3 MINIMUM SYSTEM REQUIREMENTS

These requirements are for build 5.0.0.60892 of Cambria Live, Cambria Live Broadcast Manager, and Cambria Live Editor

### 3.1 OPERATING SYSTEM

Windows 11, 10, Windows Server 2016, 2019, 2022 (Windows should be updated through Microsoft Windows Update before installing the application)

### 3.2 MOTHERBOARD

USB port for the USB license key (optional), 1 PCIe slot for each capture card (optional for capture input), 1 PCIe slot for the External Signal Input card (optional for source switching automation)

### 3.3 PROCESSOR

Intel Xeon E5-1650 v3 @ 3.50 GHz (6-Core)

### 3.4 SYSTEM MEMORY (RAM)

16 GB, 2133 MHz (4x4GB)

### 3.5 VIDEO CARD

Supports Direct3D acceleration.

### 3.6 NETWORK ADAPTER

Gigabit Ethernet (Wired Connection).

### 3.7 SYSTEM HARD DRIVE

SSD (256 GB).

# CAMBRIA LIVE CAMBRIA LIVE: TECHNICAL SPECIFICATIONS

## 3.8 RECOMMENDED SYSTEM FOR CAMBRIA LIVE AND BROADCAST MANAGER

This is the recommended configuration for both a Cambria Live (only) system and also for a Broadcast Manager installation that includes Cambria Live on the same machine. It is also recommended that the Cambria build versions are for BCM and for Live.

<b>3.8.1 Model:</b>	HP Z4
<b>3.8.2 Operating System:</b>	Windows 10 SP1 64-bit
<b>3.8.3 Processor:</b>	Intel Core i7-7820X @ 3.60GHz (8-core Skylake X)
<b>3.8.4 Memory:</b>	16 GB
<b>3.8.5 Video Card:</b>	Supports 3D acceleration
<b>3.8.6 Network Adapter:</b>	Gigabit Ethernet (Wired Connection)
<b>3.8.7 System Hard Drive:</b>	256 GB SSD

## 3.9 RECOMMENDED SETTINGS FOR CAMBRIA LIVE AND BROADCAST MANAGER

### 3.9.1 Windows Settings:

- **Disable automatic Windows Update**
- **Disable screen saver**
- **Avoid installing other programs on the Cambria Live machine**
- **Do not install applications (filter) that uses DirectShow as this could conflict with Cambria Live**
- **Please do not set any power save mode for HDD and CPU**
- **Install Cambria Live on the admin account**
- **Anti-Virus settings.** Cambria Live will be connected to an Internet connection. Ensure to install antivirus software such as Microsoft Security Essentials as necessary to avoid unwanted malware on the machine.

## 4 OPERATIONAL MODES AND LICENSING MODELS

This section describes how Cambria Live can operate and the licensing models.

# CAMBRIA LIVE CAMBRIA LIVE: TECHNICAL SPECIFICATIONS

## 4.1 OPERATIONAL MODES

### 4.1.1 Standalone operation Cambria Live Studio

Cambria Live Studio workflow: Customers can purchase and deploy licenses individually on any supported platforms.

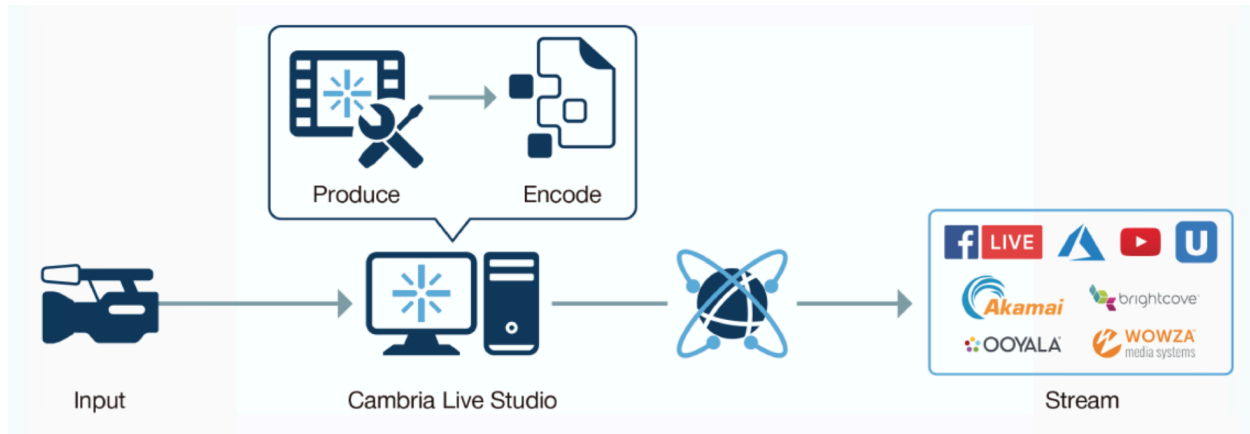

### 4.1.2 Broadcast Manager “Cluster style” operation

The Cambria Live series automates live streaming of multiple events based on your schedule. It seamlessly integrates with your existing playout and ad scheduling systems and combines live and file assets.

## CAMBRIA BROADCAST MANAGER (BCM)

BCM manages multiple Cambria Live workstations for a fully automated live streaming workflow that handles ad insertion, scheduled live streaming and more.

BCM includes a scheduler that allows broadcasters to automatically start and stop streams of registered live events. Operators can present multiple live events with individual project settings and recurring timetables. It also includes a pre-roll feature for cueing pre-prepared content before any scheduled event

# CAMBRIA LIVE CAMBRIA LIVE: TECHNICAL SPECIFICATIONS

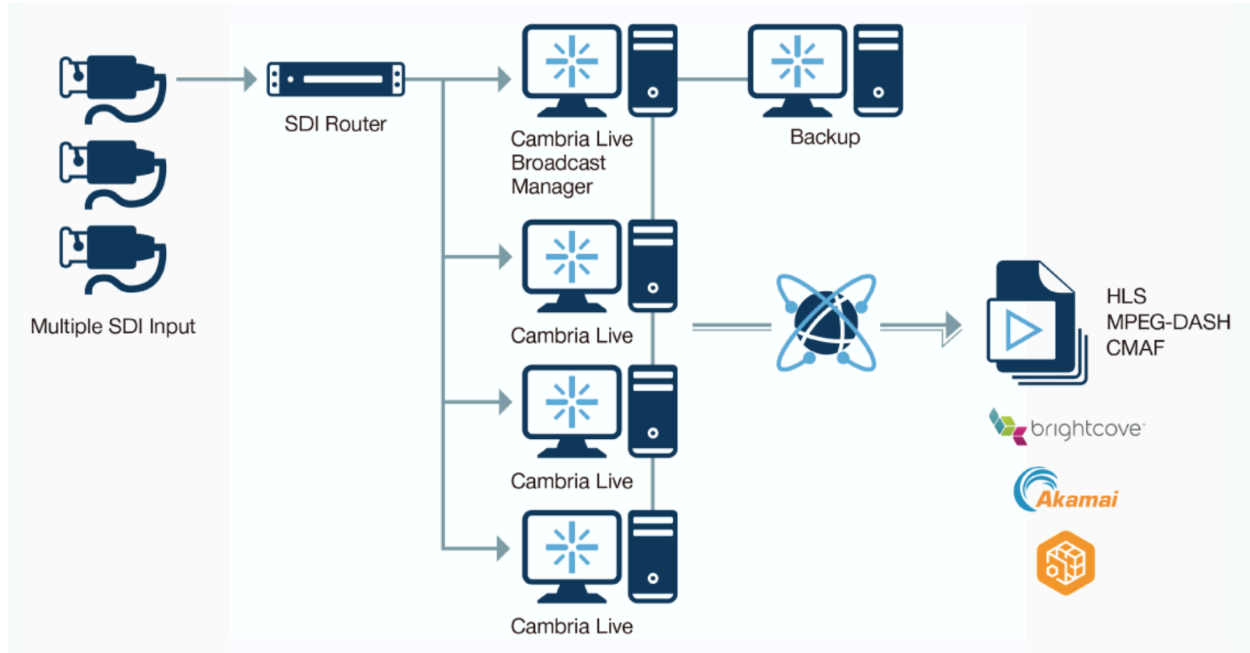

## 4.2 LICENSING MODELS

Cambria Live is purchased on a per-license basis. Each license enables Cambria Live to run on one computer at a time. Customers can license a single machine via a software license, can deploy Cambria Live on multiple machines individually via a hardware dongle, or can deploy Cambria Live over multiple computers via a floating license.

## 5 SUPPORTED FORMATS

### 5.1 LIVE INPUTS/OUTPUTS

Here are the live inputs and outputs that Cambria Live supports.

		Cambria Live DTE	Cambria Live ADE
Digital Video Inputs	HD/SD-SDI	BNCx1 (SMPTE 259M/292M/296M)	BNCx1 (SMPTE 259M/292M/296M)
	HDMI		HDMIx1 (v1.3, 30Bits/Pixel, RGB or YUV, 2.25 Gbps, SD, HD, 1080p50/60)
Digital Video Inputs	HD/SD-SDI	BNCx1 (SMPTE 259M/292M/296M)	BNCx1 (SMPTE 259M/292M/296M)
Digital Audio Inputs	HD-SD-SDI	Embedded Audio (16-ch 24-bit, 48 kHz Synchronous)	Embedded Audio (16/24/32-bit SMPTE)

# CAMBRIA LIVE CAMBRIA LIVE: TECHNICAL SPECIFICATIONS

			259M, 8-ch, 48 kHz, Synchronous)
Webcam			
Remote inputs	RTP		
	RTMP		
	SRT		
	NDI		
	Zixi/TS (via Zixi Broadcaster)		
	Web Capture		
	Cambria Live Desktop Stream		

## 5.2 IMPORT FILE FORMATS

Here are the file types recommended for importing into a Cambria Live project for deployment without slowing system performance.

Input Format	Container	Video Codec	Audio Codec
Flash Video	F4V	H.264	MPEG-2 AAC
Generic MP4	MP4	H.264	MPEG-2 AAC
Generic TS	MPEG-2 TS	H.264	MPEG-2 AAC, MPEG-1 Layer-2, AC-3*
		MPEG-2	MPEG-2 AAC, MPEG-1 Layer-2, AC-3*
Generic PS	MPEG-2 PS	MPEG-2	MPEG-2 AAC, MPEG-1 Layer-2, AC-3*
	MPEG-1 PS	MPEG-1	MPEG-2 AAC, MPEG-1 Layer-2, AC-3*
HDV	MPEG-2 TS	MPEG-2	MPEG-1 Layer 2
QuickTime**	MOV	DSV25	Linear PCM
Windows Media	WMV	Windows Media Video	Windows Media Audio
Input Format	Image Format		
Still Image	BMP, JPEG, PNG, TIF, TGA		
PowerPoint and PDF			

### 5.2.1 Source File Guidelines:

The system resources required to handle a given file may vary based on source format, source properties, and encoding attributes. CPU usage in some cases can vary up to

# CAMBRIA LIVE CAMBRIA LIVE: TECHNICAL SPECIFICATIONS

30% due to the type of source used. Listed below are guidelines that are relevant when using a machine similar to our Recommended System or Minimum System Specification. Not following these guidelines will increase your chances for video/audio stuttering in your preview windows as well as your RTMP output video.

- **Use WMV, MPEG, or H.264 files.** These formats were the focus of our testing. Other formats may be able to be used as sources, but the performance/usability of other formats have not been tested).
- **SD Resolution and Native Frame Rate.** To reduce some overhead you can use SD sources and sources with the same frame rate as the encoding target frame rate.
- **Use Seekable files.** Files that are not seekable cannot be used (Files may not be seekable for a various reasons, common cases include files with discontinuous or missing timestamps - if you encounter a file that is not seekable, please contact our support team and we can investigate the issue).
- **Use files with Closed GOPS.** MP4 files encoded with an Open GOP can take a long time to seek to specific points in the file. Switching can have a delay when switching to Open GOP MP4 files in Cambria Live. Please use Closed GOP MP4 instead.
- **Store source files locally.** To avoid some network related issues, use files stored locally. When forced to use network sources, please make sure that your read speed to the network source is fast enough to retrieve the file in real-time.
- **Avoid [\\localhost](#).** Do not use [\\localhost](#) to point to a file on the local machine to avoid Windows Media Foundation file reading issues. Please use [\\machineName](#) instead.
- **Alpha channel support.** MOV files with alpha channel are supported through the PiP/Audio column.
- **MP4 audio decoder errors.** A small subset of MP4 files may fail with an audio decoder error. If you run into this issue, please contact Capella.

## 5.2.2 Input formats:

Certain formats require a 3rd party modules / applications to be installed. Installing those modules / applications are done at your own risk. Please note that Capella is not responsible for those applications.

LIVE CAPTURE INPUTS					
	SDI	HDMI	Analog	RTP	RTMP
No Capture Card				✓	✓
AJA KONA 1 (SDI x 1)	✓			✓	✓
AJA KONA LHI (SDI x 1)	✓	✓	✓	✓	✓
AJA Corvid 44 (SDI x 4)	✓			✓	✓
AJA Corvid 88 (SDI x 8)	✓			✓	✓

RECOMMENDED FILE INPUT			
Formats	Containers	Video Codecs	Audio Codecs
Flash Video	F4V	DV25	Linear PCM
Generic MP4	MOV	H.264	MPEG-1 Layer 2
Generic PS	MP4	MPEG-1	MPEG-2 AAC
Generic TS	MPEG-1 PS	MPEG-2	Windows Media Audio
MOV	MPEG-2 PS	Windows Media Video	
PowerPoint and PDF	MPEG-2 TS		
Still Image (TIFF, TGA, BMP, JPG)			
Windows Media			

### 5.3 OUTPUT FILE FORMATS

Here are the file types recommended for importing into a Cambria Live project for deployment without slowing system performance.

Output Format	Codec Support	Targets	Other
CMAF (upload)	H.264/AAC	Akamai WebDAV AWSMediaStore AWS S3 Unified Streaming Linode Object Storage	Supports chunked transfer/encoding, low latency mode, and primary and backup workflow. Can insert EXT-X-SCITE35 tag for Ad insertion and prefetch.
MPEG-DASH (upload)	H.264/AAC	Akamai, WebDAV, AWSMediaStore, AWS S3, Linode Object Storage	Supports primary and backup workflow and low latency mode.
HLS (upload)	H.264/AAC	Akamai, WebDAV, AWSMediaStore, AWS S3, Linode Object Storage	Supports primary and backup workflow and EXT-X-SCITE35 tag for Ad insertion and prefetch, low latency mode, and AES encryption.
HLS (File)	H.264/AAC	Disk	Can insert EXT-X-SCITE35 tag for Ad insertion and prefetch and enable AES encryption.



## CAMBRIA LIVE CAMBRIA LIVE: TECHNICAL SPECIFICATIONS

Other			
File: Generic TS	MPEG-2 TS/AAC/MP EG-1 Audio Layer 2	Disk	
File: Generic MP4	MPEG-2 TS/AAC/MP EG-1 Audio Layer 2	Disk	

## SUPPORTED DESTINATIONS AND PROTOCOLS

Target	Supported Formats	Other
ABR targets	HLS/DASH/CMAF /CMAF-CTE	Native Akamai, WEBDAV, AWS Media Store, AWS S3, and File-write support for ABR targets
Brightcove	H.264/AAC	Direct account login with connection test, SSAI support via ID3 tags.
ULIZA	H.264/AAC	Direct account login with connection test.
Facebook	H.264/AAC	API level access with account access with connection test for posting to pages, setting privacy options, audience restrictions and inserting Ads. Can convert livestream to VOD.
Microsoft Azure	H.264/AAC	Direct account login with connection test.
YouTube	H.264/AAC; RTMP and MPEG DASH	API-level access with Ad insertion
Wowza	H.264/AAC	Direct account login with connection test.
Generic RTMP Server	H.264/AAC	Generic account login with connection test.
Generic server via RTP/UDP	H.264/AAC in TS stream.	Generic account login with connection test.
Generic SRT Target	H.264/AAC in TS stream	Generic account login with connection test. Can set payload size, peer latency, drop TLPKT, generate NAK report.
Zixi/TS	H.264/AAC in TS stream	Uses proprietary Zixi protocol for streaming
Iccast	H.264/AAC	Stream to Iccast server video and audio. Can stream audio only as well.

# CAMBRIA LIVE CAMBRIA LIVE: TECHNICAL SPECIFICATIONS

## LIVE OUTPUT

Destinations	Protocol	Video Codecs	Audio Codecs
Akamai	CMAF	H.264	AAC
AWS MediaStore	CMAF CTE		MP3
AWS S3	DASH		
Brightcove	HLS		
Facebook	RTMP		
Generic Server	RTP/UDP		
Microsoft Azure	SDI		
ULIZA	SRT/TS		
WebDAV			
Wowza			
YouTube			

## FILE OUTPUT

Formats	Containers	Video Codecs	Audio Codecs
Generic MP4	MP4	H.264	AAC
Generic TS	MPEG-2 TS		

## 6 PERFORMANCE BENCHMARKS

This section details performance benchmarks.

### 6.1 BENCHMARK MACHINE

Cambria Live projects can be configured in many ways, each with different requirements on resource usage. The two benchmark configurations detailed in this section are run using the same hardware configuration and can provide some insight to whether other configurations can be run successfully in real-time.

Model: HP Z4  
Operating System: Windows 10 SP1 64-bit  
Processor: Intel Core i7-7820X @ 3.60GHz (8-core Skylake X)  
Memory: 16 GB  
PCIe Slot for Capture Board: Slot 3 (<https://www.aja.com/support/kona-pc-system-configuration>)

### 6.2 BENCHMARK CONFIGURATION 1: HD I/O NO SOURCE SWITCHING

Two types of projects were tested. The first includes one 1080p SDI input and one 1080p RTMP output stream. The second includes one 1080p SDI input and one Adaptive Streaming output with 4 video layers (1080p/720p/480p/360p)

HD I/O no Source Switching	
RTMP output stream (1080p)	4 simultaneous projects on HP Z4

## CAMBRIA LIVE CAMBRIA LIVE: TECHNICAL SPECIFICATIONS

Adaptive Streaming: 4 video layers	2 simultaneous projects on HP Z4
	*** "Use only physical CPU cores" must be
Note: Testing was done without any source switching. Each SDI input was mapped to a different target output through the target ISO stream setting. Basic source properties and target settings such as frame size, frame rate, and aspect ratio are matched. Fast encoding settings consistent with our Live Streaming presets were used.	

### 6.3 BENCHMARK CONFIGURATION 2: MIXED SOURCE COMPOSITION SWITCHING

Project includes compositions created from 1080p Signal Input, Virtual Cameras, Picture-in-Picture, and Layer sources. Real-time performance is maintained when switching between these compositions and the program output is encoded to a 1080p, 480p, 360p, 240p output.

<b>Mixed Source Composition Switching</b>	
Capture Signal Input (1080p30)	1 x HD input
Virtual Cameras	5
Picture-in-Pictures	5 (2 using Videos with Alpha Layers)
Layers	5
Target Streams	5 (2 using Videos with Alpha Layers)
Note: Fast encoding settings consistent with our Live Streaming presets were used.	

## 6.3.1 Performance Considerations

- **Performance indicators:** Adding additional targets or modifying encoding settings can affect the application’s ability to maintain real-time performance. For every target, there are indicators for Processing Speed and Delivering Speed. These indicators along with the CPU Usage (found in the lower left of the application) can be used to gauge Cambria Live’s real-time performance. We recommend that users configure and test their Cambria Live projects prior to streaming Live. The indicators will be Green when the real-time speed is maintained, and will become yellow or red when real-time speed cannot be maintained. When real-time speed is not maintained dropped frames or stream disconnect can occur.
- **Optimization:** Targets outputting to different destinations but using the same exact encoding settings as an already existing target will be able to share the same encoding mappings. This will allow you to encode to more target destinations without increasing the CPU load by much.
- **Quad-Channel Memory Optimization:** We recommend that you use a Quad-Channel Memory configuration, if your computer supports it. This will reduce the chances of running into memory bandwidth bottlenecks.
- **High Memory Bandwidth Use for SDI Output:** SDI output uses up to twice the amount of memory bandwidth when compared to a RTMP streaming output of similar frame size. When using SDI output, the system will have fewer resources to maintain real-time performance.
- **2560x1440 Resolution and 60fps Setting:** Targets that are either 2560x1440 or 60fps will use more system resources than 1080p 30fps targets. The benchmarks shown in the previous section are only for 1080p 30fps targets.

## 6.4 BROADCAST MANAGER TEST CONFIGURATION

**Testing Limits:** The table below shows the maximum number of machines and programs that we have tested for Broadcast Manager and Cambria Live configuration.

BCM + Live; Configuration	
Number of BCM machines	2 (Primary and Backup)
Number of Live Machines	5
Number of concurrent programs	22 SD (480p30) or 12 HD (720p30) programs